



User Guide

Headphones

YH-E700B

EN

Contents

Introduction	4
About this User Guide	4
Cautions regarding product handling	5
Advantages of this product	6
Accessory and part names	8
Charging and Powering	11
Charging the headphones	11
Turning on the power	12
Turning off the power	13
Remaining Battery Power	14
Bluetooth® Connectivity	15
Pairing for the First Time	15
Pairing for the First Time with Google Fast Pair	17
Pairing with a Different Device	19
Connecting to a Device Already Paired	21
Connecting via cable	22
Connecting via headphone cable	22
Wearing This Product	24
Putting the headphones on	24
Operation (Audio Playback and Phone Calls)	25
Operations during audio playback	25
Talking on the phone	27
Playing back sound according to your surroundings	28
Starting the voice assistant	29

Dedicated Application 30

About the “Headphone Control” app 30
App settings 31

Troubleshooting 34

Read this first 34
Cannot connect 35
Power will not turn on 36
The product cannot be charged 37
The product does not operate or play back 38
No sound can be heard 39
Sound can only be heard from one headphone 40
Sound is not good or sounds strange 41
The sound is distorted, noisy or choppy 42
Initializing (performing a factory reset) 43
Updating the firmware 45
List of support centers 46

Appendix 47

List of operations 47
List of indicator displays and audio messages 49
Specifications 51
Optional accessories (sold separately) 53
Trademarks 54

Introduction

About this User Guide

The User Guide is intended for users of this product, and explains how to connect and operate the product.

- The precautions and other matters in this Guide are classified as follows.



WARNING

This content indicates “risk of serious injury or death.”



CAUTION

This content indicates “risk of injury.”

NOTICE

Indicates points that you must observe in order to prevent product failure, damage or malfunction and data loss, as well as to protect the environment.

NOTE

Indicates notes on instructions, restrictions on functions, and additional information that may be helpful.

- All illustrations and screens shown in this Guide are for explanatory purposes.
- All company names, product names and other such listings in this Guide are the registered trademarks or trademarks of their respective companies.
- Text labeled as [Search tag] is for the purpose of searching. These tags are used as links from the “QUICK REFERENCE GUIDE” to the “User Guide.”

Cautions regarding product handling

Please read the “Safety Brochure” included with this product, and use caution regarding the following points.

About the charging performance

This product features built-in lithium-ion batteries. Lithium-ion batteries are consumable items. To extend the life of the batteries as long as possible, use caution regarding the following.

- If the product is not used for a long period of time, it may take longer to recharge the batteries.
- When storing the product for a long time, charge the product around once every six months to avoid excessive discharge.
- If the duration of the battery’s charge is too short, it may have reached the end of its lifespan. Contact a Yamaha repair consulting center.

Advantages of this product

This product is a set of wireless headphones that connects to Bluetooth devices such as a portable music player or smartphone over the air.

This product also features “LISTENING CARE”, Yamaha’s proprietary technology for reducing ear fatigue.

High-definition playback of sound from Bluetooth devices

This product supports Qualcomm® aptX™ Adaptive as well as the Qualcomm® aptX™ Voice, SBC and AAC codecs.

Qualcomm® aptX™ Adaptive audio supports robust, high resolution Bluetooth wireless audio.

AMBIENT SOUND

This function makes it easier to hear the sounds around you, such as announcements made on public transportation, the sounds of passing cars and so on.

- “Playing back sound according to your surroundings” (p.28)

ADVANCED ANC

This feature analyzes the playback sound and outside noise, and reduces only the noise while maintaining the playback sound quality. By reducing noises from outside such as trains, buses and so on, you can absorb yourself in the music without the need to raise the volume too much.

- “Playing back sound according to your surroundings” (p.28)

LISTENING CARE

This product features LISTENING CARE, which lets you enjoy rich sound quality even at a low volume. Focusing on the characteristics of the human ear where the low- and high-end sounds become harder to hear at lower volumes, as well as how things sound differently in different listening environments, this feature corrects the sound balance for the optimal sound to match the volume. By rendering a natural sound that’s easy to listen to, this feature reduces the load on your ears caused by excessive levels.

LISTENING OPTIMIZER

This analyzes the audio in real time and adjusts the sound quality to best match how this product fits on your ears and your ear shape.

GAMING MODE

This function also makes the audio and video sound more in sync, which is useful when you are watching a video or playing a game.

In-Ear Detection

When you take off the headphones during playback, a sensor built into the headphones activates and pauses the playback of your music automatically. The music automatically starts again when you put the headphones back on. This is useful for automatically operating the playback or pause controls on a Bluetooth device, such as a portable music player or smartphone.

- “Operations during audio playback” (p.25)

Google Fast Pair

You can easily pair this product with your Android™ smartphone. Pairing is supported with Android devices than run Android OS 6.0 or later, or Google Play 11.7 or later.

- “Pairing for the First Time” (p.15)

Smartphone support

You can use this product to talk on the phone and start up the voice assistant while connected to this product.

Dedicated smartphone app: Headphone Control

Install the Headphone Control app on your smartphone to configure more detailed settings.

You can use this to switch features like AMBIENT SOUND, ADVANCED ANC, LISTENING CARE, LISTENING OPTIMIZER, GAMING MODE and In-Ear Detection ON/OFF.

NOTE

- While the AMBIENT SOUND feature makes it easier to hear sounds around you, it does not guarantee that you will be able to hear everything. You may be unable to hear the sounds around you if you've turned up the playback volume, or in certain environments.
- When using GAMING MODE, the video/audio latency may change or the sound quality and connection stability may degrade, depending on the usage environment and how you wear the product.

Related links

- “Pairing for the First Time” (p.15)
- “Operations during audio playback” (p.25)
- “Playing back sound according to your surroundings” (p.28)
- “Starting the voice assistant” (p.29)
- “About the “Headphone Control” app” (p.30)
- “App settings” (p.31)

Accessory and part names

Make sure that all of the accessories are included with this product.

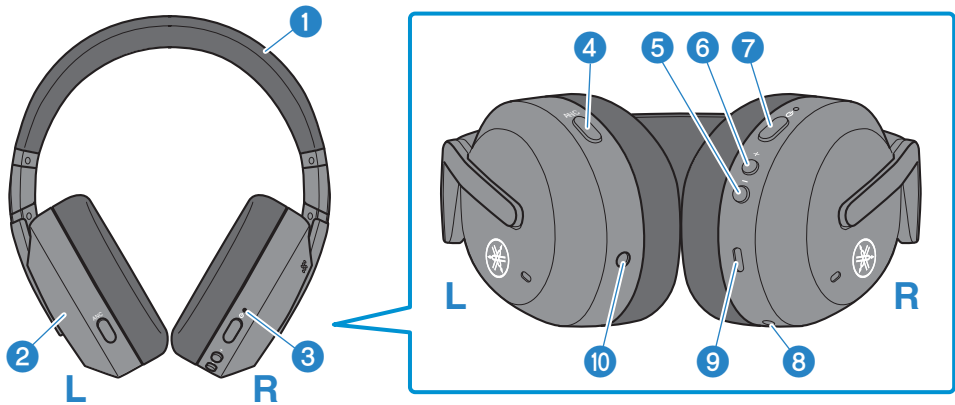

Headphones

- 1 **Headband**
- 2 **Housing**
- 3 **Indicator**
- 4 **Function key**
- 5 **- (minus) key**
- 6 **+ (plus) key**
- 7 **Power key**
- 8 **Microphone**
Captures the sound of your voice when you make a phone call.
- 9 **Charging connector**
Plug the USB power cable into the connector for charging.
- 10 **External input jack**
Connect a 3.5 mm stereo mini-plug cable here.

NOTE

The housing features a built-in microphone that captures ambient sounds. If your hand is covering the housing, effects like AMBIENT SOUND and ADVANCED ANC will not work properly, and you may hear noise.

USB power cable (20 cm (7-7/8 in); type A to C)

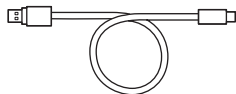

In-flight plug adaptor

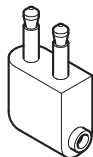

3.5 mm stereo mini-plug cable



Carrying case

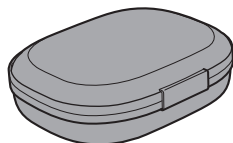

QUICK REFERENCE GUIDE

Safety Brochure

NOTE

The headphones are stored in the carrying case.

Storing the headphones in the carrying case

- Follow these steps to store this product in the carrying case.



1

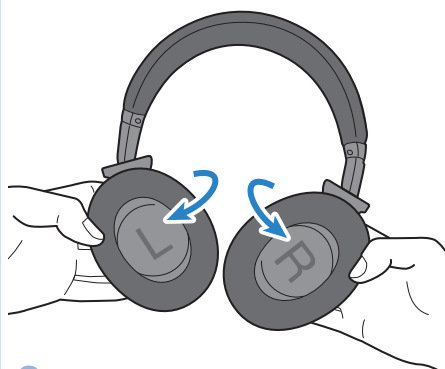

2



3

4

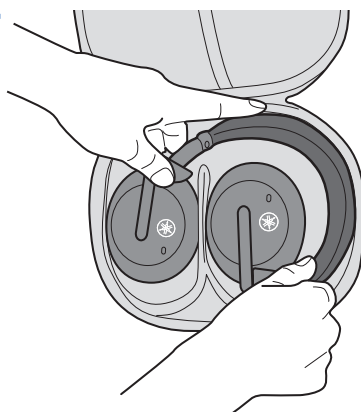

Charging and Powering

Charging the headphones

Charge the headphones before use.



CAUTION

- This product is not designed to be waterproof. Thoroughly wipe off any sweat, rainwater, seawater or other liquids before charging.
- Be sure to use the USB power cable that was included with this product.
- When using a USB power adaptor, be sure that the commercially-available adaptor is compatible with 5 V DC (at least 0.5 A) power output.
- When charging this product inside of China, be sure to use a USB power adaptor that is approved by CCC.
- Recommended charging temperatures: 5°C–40°C

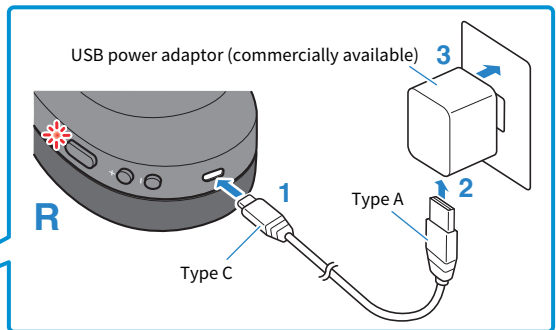

- 1 Plug the USB power cable (type C side) into the headphones charging connector.**
- 2 Plug the USB power cable (type A side) into the USB power adaptor.**
- 3 Plug the USB power adaptor into the power outlet.**

Charging will begin. The indicator lights up red during charging, and turns off when charging is completed. Charging takes about 3.5 hours.

Turning on the power

Here's how to turn this product on.

1 Hold down the power key for three seconds.

The indicators light up as shown below, and the power turns on.

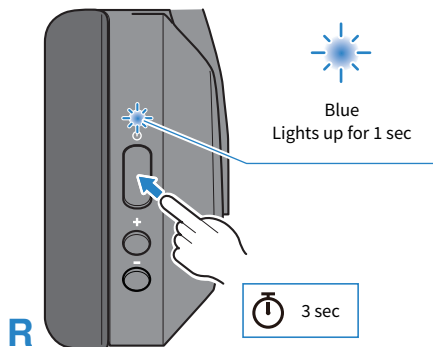

Related links

["Remaining Battery Power" \(p.14\)](#)

Turning off the power

Turn this product off.

1 Hold down the power key for three seconds.

The indicator lights up as shown below, and the power turns off.

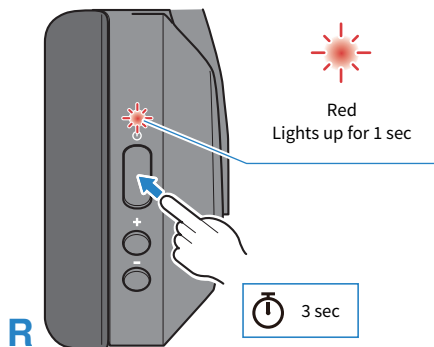

Remaining Battery Power

After this product is turned on, an audio message tells you how much battery power is left in the headphones.

- **Audio messages:**

- Battery High: plenty of charge remaining
- Battery Medium: moderate charge remaining
- Battery Low: small amount of charge remaining

Bluetooth® Connectivity

Pairing for the First Time

When first connecting this product to a Bluetooth device (such as a smartphone), follow the steps below to pair (register) this product with that device.

[Search tag] #Q02 Pairing

NOTE

You can use Google Fast Pair (described afterwards) to easily pair this product with your Android smartphone.

1 Set this product to pairing (registration) standby mode.

With the headphones powered off, hold down the power key until the indicator flashes as shown in the illustration below. You will hear the “Pairing” audio message in the headphones, and the product enters pairing (registration) standby mode.

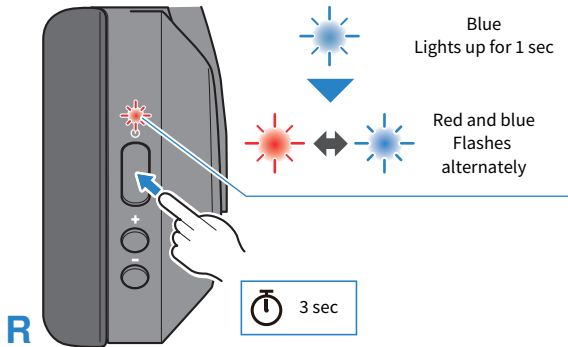

2 Activate Bluetooth on your Bluetooth device.

A list of Bluetooth devices that can be connected will be shown.

3 Select this product from the list on your Bluetooth device.

Select the listing that reads “Yamaha...” and not the listing that reads “LE-Yamaha...”.

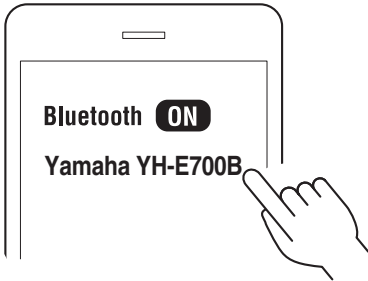

Once connected, the indicators on this product light up as shown below. You will hear the “Connected” audio message in the headphones.

Pairing and connection are now complete.

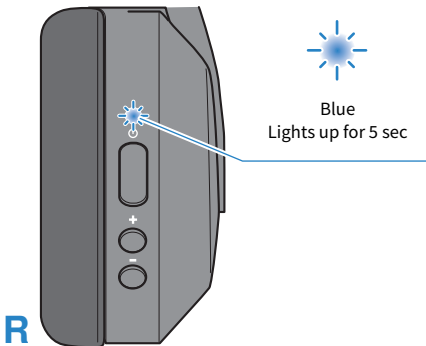

NOTE

- Pairing standby mode will automatically end on this product after about two minutes. To pair again or if the connection was unsuccessful, go back to step 1.
- This product cannot be paired with devices that require a passkey when pairing, as this feature is unsupported.

Related links

- “Pairing with a Different Device” (p.19)
- “Connecting to a Device Already Paired” (p.21)
- “About the “Headphone Control” app” (p.30)

Pairing for the First Time with Google Fast Pair



Fast Pair

Follow the steps below to easily pair (register) this product with your Android device that supports Google Fast Pair.

1 Set this product to pairing (registration) standby mode.

With this product powered off, hold down the power key until the indicator flashes as shown in the illustration below. You will hear the “Pairing” audio message, and the product enters pairing (registration) standby mode.

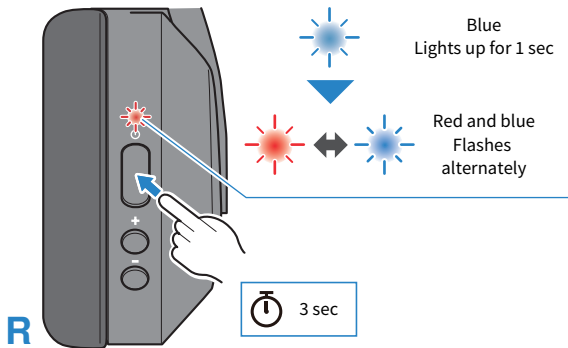

2 Activate Bluetooth on your Bluetooth device, and move the device close to this product.

A notification will be shown on your Android device.

3 Tap the notification on your Android device.

The device will then finish pairing with this product.

If successfully connected, the indicator on this product lights blue (for about five seconds), and you will hear the “Connected” audio message.

Pairing and connection are now complete.

NOTE

- To use Google Fast Pair, you'll need to configure your Google account and connect to a network.
- Pairing is supported with Android devices running Android OS 6.0/Google Play 11.7 or later.

Related links

- “Pairing with a Different Device” (p.19)
- “Connecting to a Device Already Paired” (p.21)
- “About the “Headphone Control” app” (p.30)

Pairing with a Different Device

Follow the steps below to pair with another Bluetooth device, or to try pairing with the same device again.

[Search tag] #Q02 Pairing

1 Set this product to pairing (registration) standby mode.

With this product powered off, hold down the power key until the indicator flashes as shown in the illustration below. You will hear the “Pairing” audio message, and the product enters pairing (registration) standby mode.

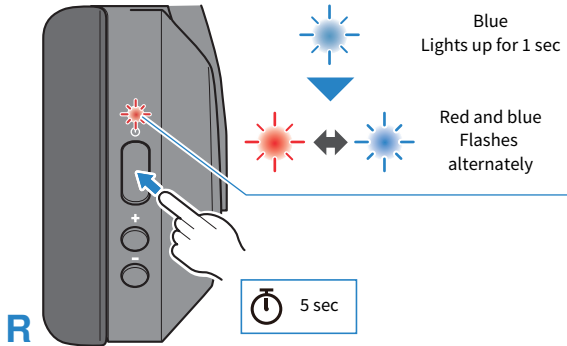

2 Activate Bluetooth on the Bluetooth device.

A list of Bluetooth devices that can be connected will be shown.

3 Select this product from the list on your Bluetooth device.

Select the listing that reads “Yamaha...” and not the listing that reads “LE-Yamaha...”.

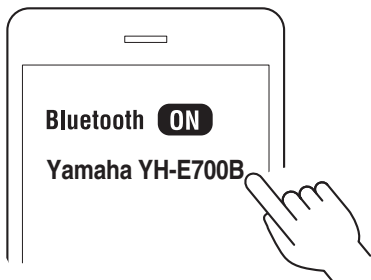

Once connected, the indicators on this product light up as shown below. You will hear the “Connected” audio message in the headphones.

Pairing and connection are now complete.

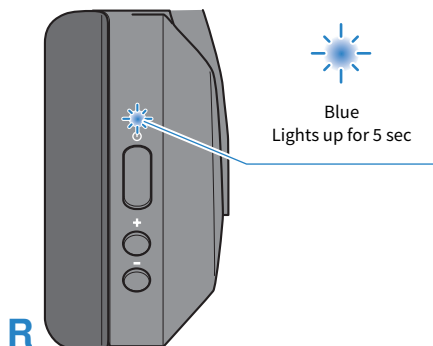

NOTE

- Pairing standby mode will automatically end on this product after about two minutes. To pair again or if the connection was unsuccessful, go back to step 1.
- Up to seven Bluetooth devices can be registered with this product. If you pair a device beyond the maximum number, the information for device you first paired (the oldest pairing) will be deleted.
- This product does not support multi-point connection (connection to multiple devices at the same time).
- This product cannot be paired with devices that require a passkey when pairing, as this feature is unsupported.

Related links

- “Pairing for the First Time” (p.15)
- “Connecting to a Device Already Paired” (p.21)
- “About the “Headphone Control” app” (p.30)

Connecting to a Device Already Paired

Here's how to connect to a Bluetooth device to which this product has already been paired.

1 Activate Bluetooth on the Bluetooth device.

2 Turn this product on.

The product automatically connects to the last Bluetooth device to which it was connected. Once connected, the indicators light up as shown below.

If the connection cannot be automatically made, this product enters pairing standby mode. Try connecting to this product from the Bluetooth device instead.

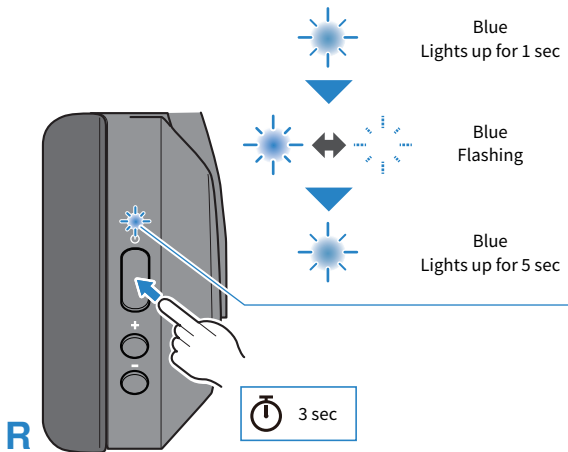

Once connected, you will hear the “Connected” audio message on this product. Pairing is now complete.

NOTE

This product does not support multi-point connectivity (connection to multiple devices at the same time).

Related links

- “Pairing for the First Time” (p.15)
- “Pairing with a Different Device” (p.19)

Connecting via cable

Connecting via headphone cable

You can connect this product to the headphone output jack of an external device by using the 3.5 mm stereo mini-plug cable (included).

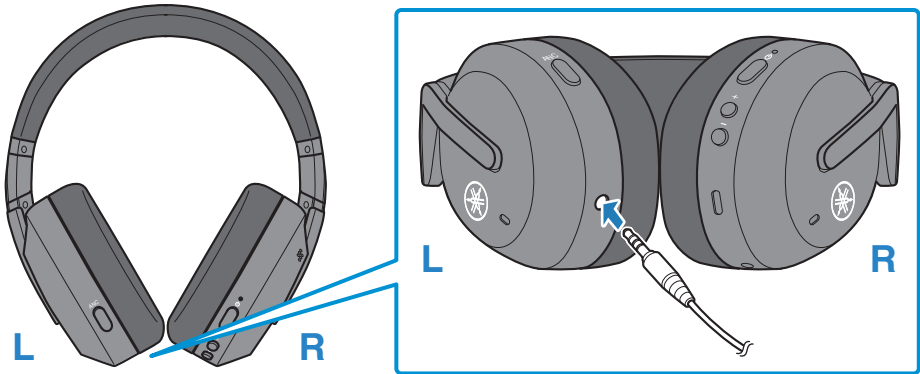

- When connected via cable, the following functions are available even while you're using this product.
 - Turning the power on/off
 - Switching between AMBIENT SOUND/ADVANCED ANC/OFF
- The following functions are not available when connected via cable while you're using this product.
 - Connecting to a Bluetooth device
 - Using the + (plus) and - (minus) keys
 - Using the pause/play keys
 - Using the GAMING MODE ON/OFF keys
 - Phone calls
 - Using the keys to start/stop the voice assistant
 - Operating this product via the Headphone Control smartphone app
- When using this product with the cable connected, you can still use it as a regular pair of headphones when the power is off.

Connecting via cable > Connecting via headphone cable

NOTE

- You can also use a commercially available headphone cable (3.5 mm stereo mini-plug).
- Use the included in-flight plug adaptor to connect this product to the headphones jack on an airplane seat.

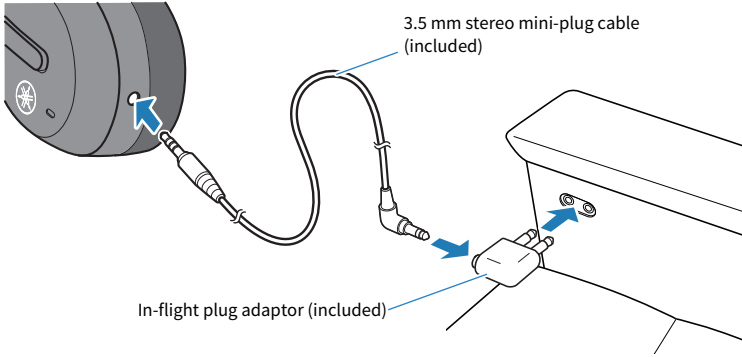

Wearing This Product

Putting the headphones on

Check the markings on the headphones for the L (left) and R (right) sides when putting the headphones on.



Operation (Audio Playback and Phone Calls)

Operations during audio playback

You can operate this product using the respective keys during playback as follows.

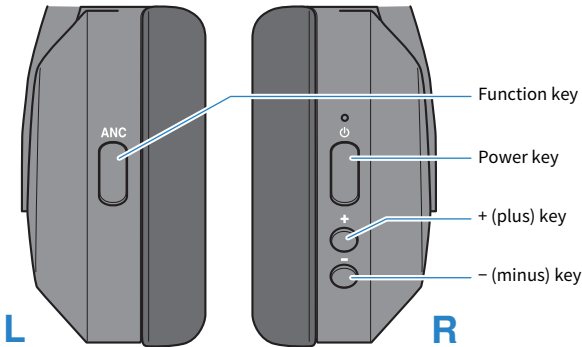

Volume controls

- Turn the volume up
Press the + (plus) key.
- Turn the volume down
Press the - (minus) key.

Playing back audio

- Pause/play
Press the power key.
- Skip to the next track
Hold down the + (plus) key for about one second.
- Go back to the beginning of the track (while in the middle of the track), or back to the previous track (when at the beginning of a track)
Hold down the - (minus) key for about one second.
The operation may differ, depending on the Bluetooth device or app you use.

In-Ear Detection

- Pause or restart playback
When you take off the headphones during playback, a built-in sensor activates and pauses the playback of your music automatically. The music automatically starts again when you put the headphones back on.

GAMING MODE

This function also makes the audio and video sound more in sync, which is useful when you are watching a video or playing a game.

1 Press the function key twice.

The function switches between ON and OFF each time you press the key twice in a row.

The default setting is OFF.

- ON: the “Gaming On” audio message is heard.
- OFF: the “Gaming Off” audio message is heard.

NOTE

- In regard to In-Ear Detection, please observe the following.
 - The default setting is ON. Use the “Headphone Control” smartphone app to turn this feature “OFF.”
 - Before wearing this product, turn down the volume on the connected device.
 - In-Ear Detection may not work correctly if this product is not positioned correctly on your head and ears.
- Regarding GAMING MODE, please observe the following.
 - When Bluetooth is disconnected, the GAMING MODE setting switches to OFF.
 - GAMING MODE does not work during a phone call.
 - You can also set this with the Headphone Control smartphone app.
- When connecting to a device (such as a smartphone) on which the volume can be adjusted, you can also adjust the volume using that device.
- To select a song for playback, operate the connected device.

Related links

“App settings” (p.31)

Talking on the phone

When connecting to a Bluetooth device, you can talk, adjust the volume and so on using this product. Operate this product as follows.

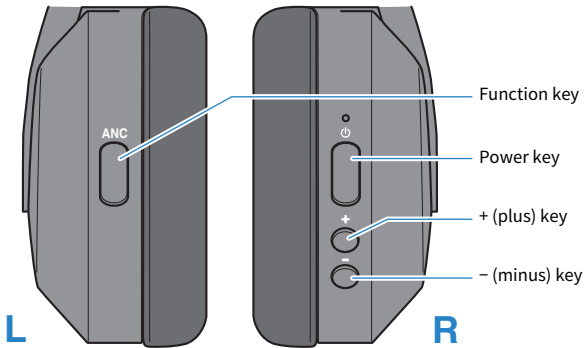

- Receive a phone call
When a phone call comes in, press the power key.
- End a phone call
During the phone call, press the power key for about one second.
- Ignore a call
When a phone call comes in, press the power key for about one second.
Take your finger off the key once you hear the beeping sound.
- Turn the volume up
During the phone call, press the + (plus) key.
- Turn the volume down
During the phone call, press the - (minus) key.

NOTE

When a call is coming in, any music being played will pause. Audio playback will automatically resume when the call ends or you ignore the call.

Playing back sound according to your surroundings

Enabling AMBIENT SOUND makes it easier to hear the sounds around you, such as announcements made on public transportation, the sounds of passing cars and so on.

Also, when you enable ADVANCED ANC, the headphones reduce only the external noise while maintaining playback sound quality, eliminating the need to turn the volume up too high.

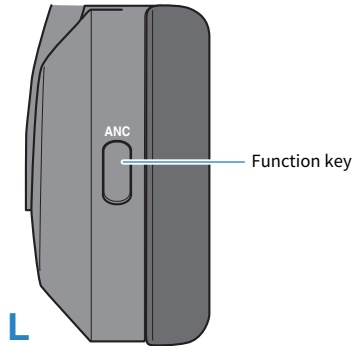

Switching between AMBIENT SOUND/ADVANCED ANC/OFF

1 Press the function key once.

The function switches each time you press the function key.

OFF → AMBIENT SOUND → ADVANCED ANC → back to OFF

- When OFF → AMBIENT SOUND: a sound effect is heard.
- When AMBIENT SOUND → ADVANCED ANC: a sound effect is heard.
- ADVANCED ANC → OFF: the “Off” audio message will be heard from this product.

NOTE

- The default setting is OFF.
- While the AMBIENT SOUND feature makes it easier to hear sounds around you, it does not guarantee that you will be able to hear everything. You may be unable to hear the sounds around you if you've turned up the playback volume, or in certain environments.
- Depending on the type of sound you are playing back and the surrounding environment, ambient sounds may not be so easy to hear. In this case, pause the playback.
- You can also set the AMBIENT SOUND and ADVANCED ANC features with the Headphone Control app.
- Do not cover the housing with your hand. If your hand is covering the housing, AMBIENT SOUND and ADVANCED ANC will not work properly, and you may hear noise.

Related links

- “Operations during audio playback” (p.25)
- “App settings” (p.31)

Starting the voice assistant

If connecting this product to a Bluetooth device that supports the use of Siri, Google Assistant or similar features, you can control the voice assistant with this product.

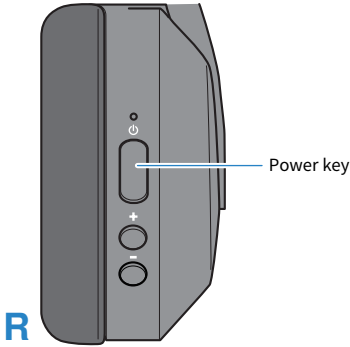

- Start voice assistant
Press the power key twice.
- Stop voice assistant
 - When using Siri
Press the power key twice.
 - When using Google Assistant
Operate using your Bluetooth device.

NOTE

The operations for the voice assistant feature will vary depending on your Bluetooth device. See the user's manual of your Bluetooth device for details.

Dedicated Application

About the “Headphone Control” app

The Headphone Control smartphone app is a dedicated app for getting the best sound quality from your Yamaha earbuds or headphones.

[Search tag] #Q03 App



This app will let you do the following.

- Show the status of your earbuds/headphones (such as remaining battery power)
- Make detailed settings on your earbuds/headphones

Install the app from the App Store (iOS devices) or Google Play (Android devices). See the information about the app on each store for details.

App settings

This explains the settings and items you can check using the Headphone Control app. Check the settings for each function and the latest information from the app screen. [Search tag] #Q03 App

NOTE

The app screen and items may differ, depending on your product.

Main screen

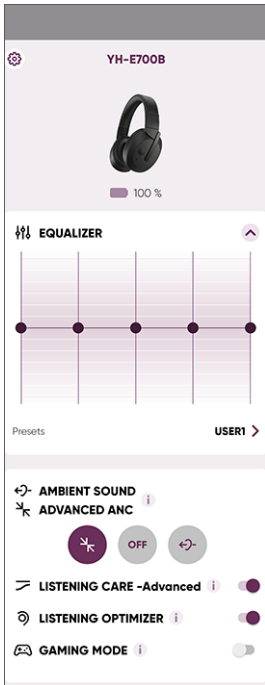

- EQUALIZER

This is a 5-band graphic equalizer that you can customize to get the sound you want.

- AMBIENT SOUND

This function makes it easier to hear the sounds around you, such as announcements made on public transportation, the sounds of passing cars and so on.

- ADVANCED ANC

This feature reduces only the external noise while maintaining playback sound quality, eliminating the need to turn the volume up too high.

Dedicated Application > App settings

- LISTENING CARE

When LISTENING CARE is enabled, this product automatically adjusts the sound quality according to the playback volume. This feature adjusts the frequency balance, offering rich sound quality playback even at a low volume.

- LISTENING OPTIMIZER

When you enable the LISTENING OPTIMIZER, the audio is analyzed in real time and the sound quality is adjusted to best match how this product fits on your ears and your ear shape.

- GAMING MODE

This function also makes the audio and video sound more in sync, which is useful when you are watching a video or playing a game.

NOTE

- The AMBIENT SOUND does not guarantee that you will be able to hear everything. You may be unable to hear the sounds around you if you've turned up the playback volume, or in certain environments.
- When using GAMING MODE, the video/audio latency may change or the sound quality and connection stability may degrade, depending on the usage environment and how you wear the product.

Settings screen

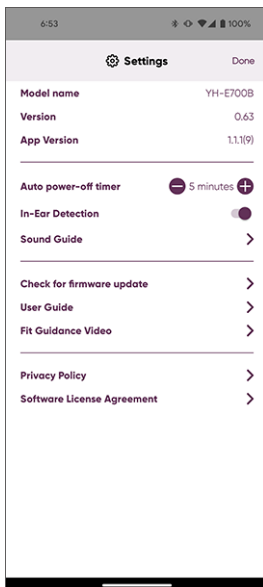

- Auto power-off timer

Sets the time it takes for the power to turn off after Bluetooth has been disconnected.

- Sound Guide

Use this to set the audio messages, sound effects, operating sounds and other sounds that you hear in the headphones.

Dedicated Application > App settings

- In-Ear Detection

When you take off the headphones during playback, a built-in sensor activates and pauses the playback of your music automatically. The music automatically starts again when you put the headphones back on.

- Check for firmware update

Checks whether new firmware has been released, and performs updates.

Use the latest available firmware version.

- User Guide

Accesses the User Guide.

Troubleshooting

Read this first

If this product does not operate normally while you are using it, first check the following.

[Search tag] #Q01 Troubleshooting

● **Turn the power off and then on again.**

If this does not solve the problem, initialize (factory reset) the product.

- “Initializing (performing a factory reset)” (p.43)

● **Make sure that this product has been sufficiently charged.**

- “Charging the headphones” (p.11)

● **Update the firmware of this product to the latest version.**

- “Updating the firmware” (p.45)

● **Check the following items according to the trouble you are experiencing.**

- “Cannot connect” (p.35)
- “Power will not turn on” (p.36)
- “The product cannot be charged” (p.37)
- “The product does not operate or play back” (p.38)
- “No sound can be heard” (p.39)
- “Sound can only be heard from one headphone” (p.40)
- “Sound is not good or sounds strange” (p.41)
- “The sound is distorted, noisy or choppy” (p.42)
- “Initializing (performing a factory reset)” (p.43)

Cannot connect

● **The product is not pairing correctly.**

If the information for this product still remains in the list of connected devices on your Bluetooth device, delete that information and try pairing again.

- “Pairing with a Different Device” (p.19)

● **The information for a Bluetooth device that was registered on this product was deleted.**

If you pair a device beyond the maximum number of pairable Bluetooth devices, the information for device you first paired (the oldest pairing) is deleted. Pair this product once more.

- “Pairing with a Different Device” (p.19)

● **This product may already be connected to another Bluetooth device.**

On your Bluetooth device, remove the connection with this product and then connect this product again.

● **This product and your Bluetooth device may be too far apart.**

Move this product closer to the Bluetooth device.

● **The Bluetooth device may already be connected to a different device.**

Try disconnecting from the Bluetooth device, and then connect with this product.

- “Connecting to a Device Already Paired” (p.21)

● **Bluetooth may be deactivated on the Bluetooth device.**

Turn Bluetooth on, and then connect with this product.

- “Connecting to a Device Already Paired” (p.21)

● **A device that emits electromagnetic waves (such as a microwave oven, Wi-Fi access point and so on) might be nearby.**

Do not use this product near other devices that emit electromagnetic waves.

● **A 3.5 mm stereo mini-plug may have been connected (when connected via Bluetooth).**

Remove the 3.5 mm stereo mini-plug cable, and then connect your Bluetooth device.

● **The cable may not be correctly connected (when connected via cable).**

Connect the 3.5 mm stereo mini-plug cable jack of this product correctly to your external device.

● **You may be using an unsupported Bluetooth device.**

This product cannot be paired with devices that require a passkey when pairing, as this feature is unsupported.

Power will not turn on

● **There may not be enough battery power left.**

Charge this product.

- “Charging the headphones” (p.11)

● **The product is temporarily not functioning in a stable way.**

Turn the power off and then on again.

If this does not solve the problem, initialize (factory reset) the product.

- “Initializing (performing a factory reset)” (p.43)

The product cannot be charged

- **Your computer is not turned on (when charging from your computer).**
Turn the power of your computer on, and then charge this product.
- **You may have been using a USB power cable other than the one included with this product.**
Use the included USB power cable to make sure the product correctly charges.

The product does not operate or play back

● **This product may be charging.**

You cannot use this product while it is charging. Use the headphones after charging is finished.

● **There is not enough battery power.**

Charge this product.

- “Charging the headphones” (p.11)

● **The product is temporarily not functioning in a stable way.**

Turn the power off and then on again.

If this does not solve the problem, initialize (factory reset) the product.

- “Initializing (performing a factory reset)” (p.43)

No sound can be heard

● **The product is not connected to a Bluetooth device.**

Pair this product.

- “Pairing for the First Time” (p.15)
- “Pairing with a Different Device” (p.19)

● **The volume is too low.**

Raise the volume.

- “Operations during audio playback” (p.25)

● **The audio stopped playing back.**

Start playback.

- “Operations during audio playback” (p.25)

● **The headphones are not worn in the correct position while In-Ear Detection is on.**

Wear this product in the correct position.

- “Putting the headphones on” (p.24)
- “Operations during audio playback” (p.25)

Sound can only be heard from one headphone

● **The product is temporarily not functioning in a stable way.**

Turn the power off and then on again.

If this does not solve the problem, initialize (factory reset) the product.

- “Initializing (performing a factory reset)” (p.43)

● **The signal may not be coming in clearly, making the connection unstable.**

Move away from wireless devices such as access points, or appliances that produce electromagnetic waves such as microwave ovens. Turn the power off and then on again.

● **You may be using a smartphone app that generates sound from only one channel.**

Check whether you can hear sound coming from both left and right channels by playing back sound from a different app.

● **The connection information for the registered Bluetooth device may not be working properly.**

Delete the Bluetooth device’s connection information, and then pair this product with the device.

- “Pairing with a Different Device” (p.19)

● **The cable might not have been correctly connected (when using the 3.5 mm stereo mini-plug cable).**

Connect the 3.5 mm stereo mini-plug cable jack of this product correctly to your external device.

Sound is not good or sounds strange

● **You might be wearing the headphones on the wrong sides (L/R).**

Check whether the left (L) and right (R) sides are facing correctly when you wear this product.



- “Putting the headphones on” (p.24)

The sound is distorted, noisy or choppy

● **The signal may not be coming in clearly, making the connection unstable.**

Move away from wireless devices such as access points, or appliances that produce electromagnetic waves such as microwave ovens.

Try placing the connected Bluetooth device as close to this product as you can.

Devices with wireless network connectivity may transmit signals that obstruct Bluetooth communications. In this case, turn off the wireless network connectivity feature on your Bluetooth device.

● **The product is temporarily not functioning in a stable way.**

Turn the power off and then on again.

If this does not solve the problem, initialize (factory reset) the product.

- “Initializing (performing a factory reset)” (p.43)

● **GAMING MODE is ON.**

Set GAMING MODE to OFF.

When using GAMING MODE, the video/audio latency may change or the sound quality and connection stability may degrade, depending on the usage environment and how you wear the product.

- “Operations during audio playback” (p.25)
- “App settings” (p.31)

Initializing (performing a factory reset)

Follow the steps below to initialize (perform a factory reset on) this product.

[Search tag] #Q04 Reset

Initializing (performing a factory reset)

This will restore all settings of this product to their factory defaults. The information for devices registered (paired) will be deleted.

1 Charge this product.

The indicators light up red

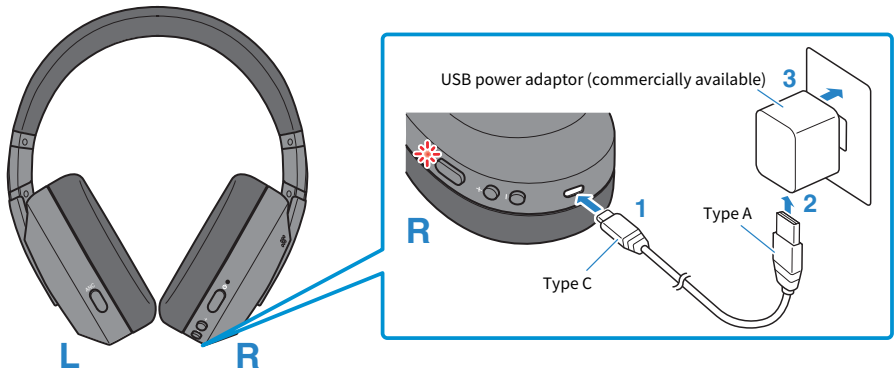

2 Once this product has charged, hold down the power key for 10 seconds.

Make sure that the indicator lights up as shown below.

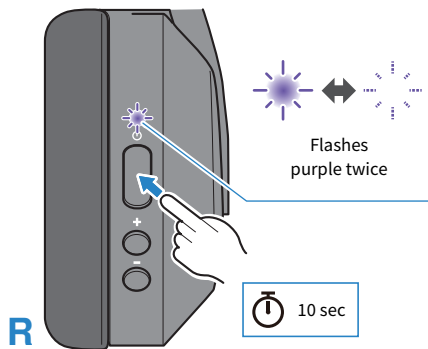

The headphones are now initialized (factory reset).

Troubleshooting > Initializing (performing a factory reset)

Related links

“Pairing for the First Time” (p.15)

Updating the firmware

Update the firmware on this product with the Headphone Control app.

The firmware on this product can be updated to add new functionality, rectify product issues and so on. For more details on the contents of updates, see the product information page on the Yamaha website.

NOTICE

- For stable data communication between this product and your Bluetooth device, update the firmware in a place where the signal is good. Do not do the following while the firmware is being updated.
 - Turning this product off
 - Closing the Headphone Control app, or using another app
 - Turning your smartphone off
 - Canceling the connection between your smartphone and this product

1 On the main screen of the Headphone Control app, open the menu.

2 Tap “Check for firmware update”.

If new firmware has been released, you will see instructions on how to perform the update. Install the firmware by following the instructions on the screen.

Related links

- “About the “Headphone Control” app” (p.30)
- “App settings” (p.31)

List of support centers

If the trouble still cannot be solved, please contact us for product support as shown below.

For customers within Japan

- Please contact the store where you purchased this product, or the Product Support Center as listed in the “QUICK REFERENCE GUIDE” included with this product.

For customers outside of Japan

- Please contact your nearest authorized Yamaha dealer or service center.
<https://manual.yamaha.com/av/support/>

Appendix

List of operations

The main operations of this product are as shown below.

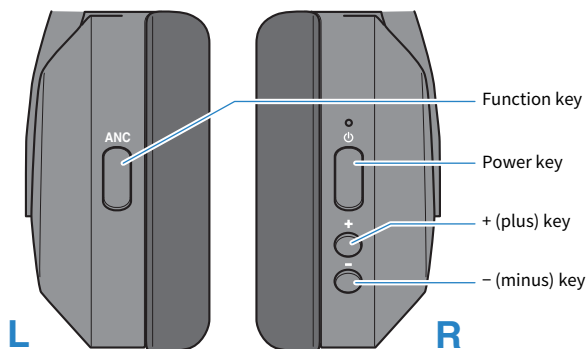

- Power on
Power key (hold down for about 3 seconds)
- Power off
Power key (hold down for about 3 seconds)

Volume

- Volume up
+ (plus) key
- Volume down
- (minus) key

Audio playback

- Pause/play
Power key
- Skip to the next track
+ (plus) key (pressed for about 1 second)
- Go back to the beginning of the song, or go back to the previous song
- (minus) key (pressed for about 1 second)
The operation may differ, depending on the Bluetooth device or app you use.

Selecting the modes

- Switch between AMBIENT SOUND/ADVANCED ANC/OFF
Function key (press quickly once)

Appendix > List of operations

- Switch GAMING MODE ON/OFF
Function key (press quickly twice)

Phone calls

- Receive a phone call
Power key
- End a phone call
Power key (hold down during a call for at least 1 second)
- Ignore a call
Power key (hold down when a call is coming in for at least 1 second)
- Turn the volume up
+ (plus) key (during a call)
- Turn the volume down
– (minus) key (during a call)

Other functions

- Start pairing
 - Hold down the power key with the power off (pressed for about 5 seconds)
- Start voice assistant
Power key (press quickly twice)
- End voice assistant (Siri only)
Power key (press quickly twice)

List of indicator displays and audio messages

The indicator displays and audio messages on this product are shown below.

Indicator display

- Power on
Lights up for 1 second (blue) and turns off
- Standby mode for pairing with Bluetooth device
Flashes (between red and blue alternately)
- Searching for paired Bluetooth device
Flashes (blue)
- Finished connecting to Bluetooth device
Lights up (blue, for approx. 5 sec) and turns off
- Power off
Lights for 1 second (red) and turns off

Indicator display when charging

- Charging
Lights up (red)
- Charging completed
Not lit

Audio messages

- Battery High
Plenty of battery charge remaining
- Battery Medium
Moderate battery charge remaining
- Battery Low
Small amount of battery charge remaining
- Pairing
Start pairing (device registration)
- Pairing Failed
Pairing unsuccessful
- Connected
Finished connecting to Bluetooth device
- Disconnected
Disconnected from Bluetooth device
- Off
Disables AMBIENT SOUND, ADVANCED ANC
- Gaming On
GAMING MODE enabled

- Gaming Off
Disables GAMING MODE

Related links

- “Charging the headphones” (p.11)
- “Turning on the power” (p.12)
- “Turning off the power” (p.13)
- “Remaining Battery Power” (p.14)
- “Pairing for the First Time” (p.15)
- “Pairing with a Different Device” (p.19)
- “Connecting to a Device Already Paired” (p.21)
- “Playing back sound according to your surroundings” (p.28)

Specifications

The specifications of this product are as shown below.

- Driver type
Over-ear
- Driver unit
40 mm
- Frequency range
8–20,000 Hz (when connected via cable)
- Bluetooth version
5.2
- Supported profiles
A2DP, AVRCP, HFP, HSP
- Supported codecs
SBC, AAC, Qualcomm® aptX™ Adaptive, aptX Voice
- Supported content protection (Japan only)
SCMS-T
- RF output power
Class 2
- Maximum communication range
10 m (without obstructions)
- Maximum number of pairable devices
7
- Analog input jack
φ3.5 mm stereo mini jack

Microphone for phone calls

- Driver type
MEMS
- Directivity
Omnidirectional
- Frequency range
20–10,000 Hz

Rechargeable battery

- Internal rechargeable battery
Lithium-ion battery
- Charging time (to full capacity)
Approximately 3.5 hours
- Continuous playback time
Approx. 32 hours maximum

Appendix > Specifications

- Continuous playback time after 10 minutes of charging
Approx. 2 hours maximum
- Temperature range for usage (when charging)
5°C–40°C
Charge this product within the listed temperature range.

General

- Weight
335 g (11.82 oz)

* The contents of this User Guide apply to the latest specifications as of the publishing date. For the latest version of the User Guide, refer to the Yamaha website.

Optional accessories (sold separately)

The earpads attached to this product and the included carrying case are also available separately as an optional purchase.

- HEP-70 Earpads

Trademarks

The trademarks used in this guide are as follows.

The Bluetooth® word mark and logos are registered trademarks owned by Bluetooth SIG, Inc. and any use of such marks by Yamaha Corporation is under license. Other trademarks and trade names are those of their respective owners.

Qualcomm aptX is product of Qualcomm Technologies, Inc. and/or its subsidiaries.

Qualcomm is a trademark registered by Qualcomm Incorporated in the U.S.A. and other countries.

Android and Google Play

Android and Google Play are trademarks of Google LLC.

App Store

App Store is a service mark of Apple Inc., registered in the U.S. and other countries.

Siri

Siri is a trademark of Apple Inc., registered in the U.S. and other countries and regions.

License information

See the website below for information on the third-party software used by this product.

<https://manual.yamaha.com/av/22/yhe700b/licenses.html>

Yamaha Global Site
<https://www.yamaha.com/>

Yamaha Downloads
<https://download.yamaha.com/>

© 2023 Yamaha Corporation

Published 01/2023 AMOD-A0

AV21-0078