

Assembly Instructions for Plasma/LCD TV Stand



Thank you for choosing our Plasma/LCD TV Stand, this stand was designed to mount flat panel televisions to a floor stand, weighting up to 60kgs.





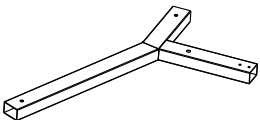
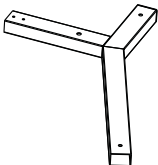
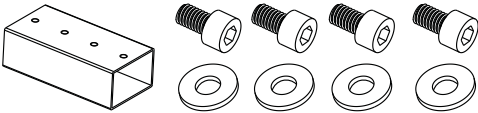
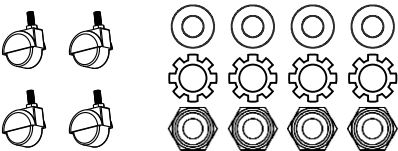

Safety Warning: If you do not understand these directions, or have any doubts about the safety of the installation, please call a qualified contractor. Check carefully to make sure there are no missing or defective parts. Never use defective parts. Improper installation may cause damage or serious injury. Do not use this product for any purpose that is not explicitly specified in this manual. We can not be liable for damage or injury caused by incorrect mounting, incorrect assembly, or incorrect use.

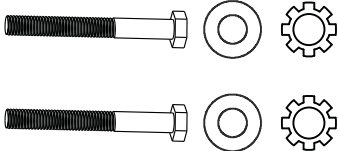
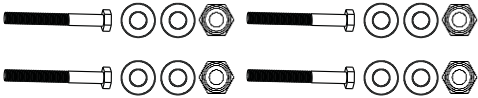

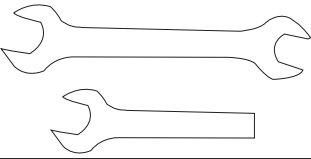
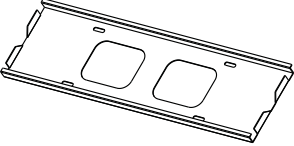
Note: We makes every effort to assure all necessary television mounting hardware is included. If the hardware you need is not included please consult your local hardware store.

Required Tools: Phillips screw driver.

Supplied Parts

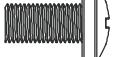
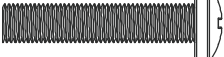
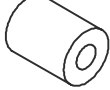
No.	Picture	Description	Quantity
1		Stand Base (Left)	1
2		Stand Base (Right)	1
3		Hardware for base connection Square tube ----- 1 pc M6 bolt ----- 4 pcs M6 washer ----- 4 pcs	1
4		Wheel and hardware Wheel----- 4 pcs M10 nut ----- 4 pcs M10 washer ----- 4pcs M10 spring washer ----- 4pcs	1
5		Long Metal Tube	2
6		Hardware for connect tube and base M12 bolt ----- 2 pcs M12 washer ----- 2pcs M12 spring washer ----- 2pcs	1
7		Hardware for connect tube & bracket M8 bolt ----- 4 pcs M8 washer ----- 8pcs M8 nut ----- 4pcs	1

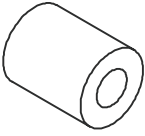
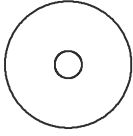
No.	Picture	Description	Quantity
8		Wrench Set	1
9		Plate	1
10		Monitor Bracket	2
11		M5x12 Bolt	4
12		M5x30 Bolt	4
13		M6x12 Bolt	4
14		M6x35 Bolt	4
15		M8x16 Bolt	4
16		M8x40 Bolt	4
17		M4/M5 Spacer	4

No.	Picture	Description	Quantity
18		M6/M8 Spacer	4
19		M4/M5 Washer	8
20		M6/M8 Washer	4

Step 1, Connect the base of the stand.

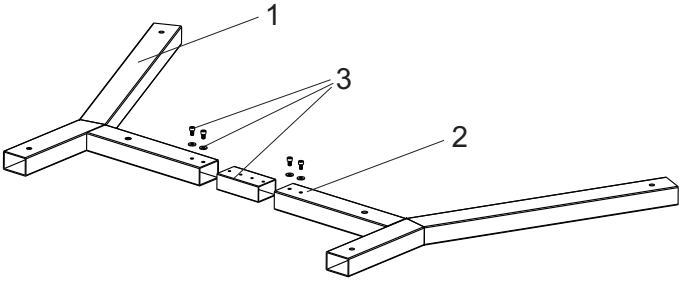

Step 2, Install the four wheels on the stand base.

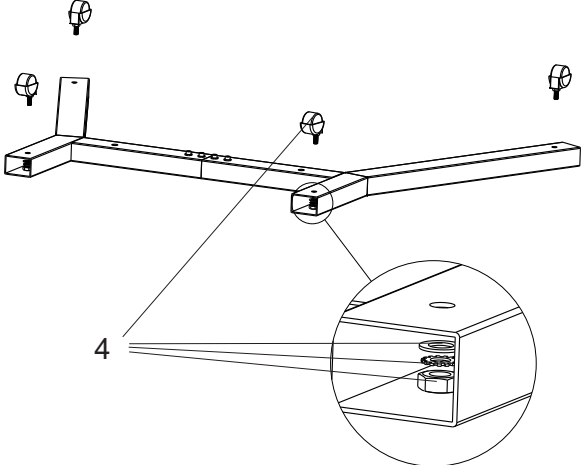

Step 3, Install tubes to base.

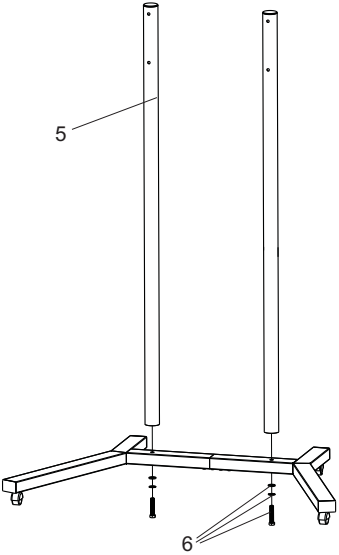

Step 4, Install the bracket on the tubes.

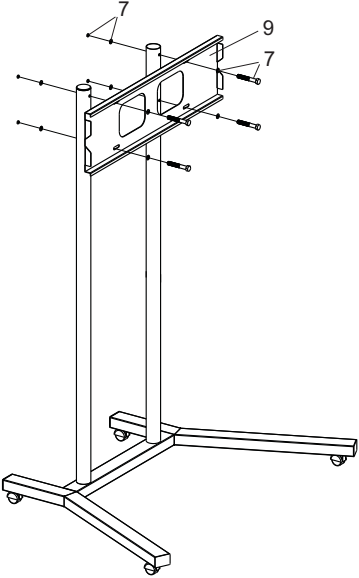

Step 5: Mounting Monitor Brackets to a television with a Flat Back

First, determine the diameter of the Bolt(11,13,15) your TV requires by hand threading them into the threaded insert on the back of the TV. If you encounter and resistance, pls stop immediately! Once you have determined the correct diameter, see the appropriate diagram below. You will thread the Bolt through the appropriate Washer(19,20), the Monitor Bracket(10), and finally into the TV. Make sure the Monitor Brackets are vertically centered and level with each other.

M4 Diameter Bolt(have not supplied)

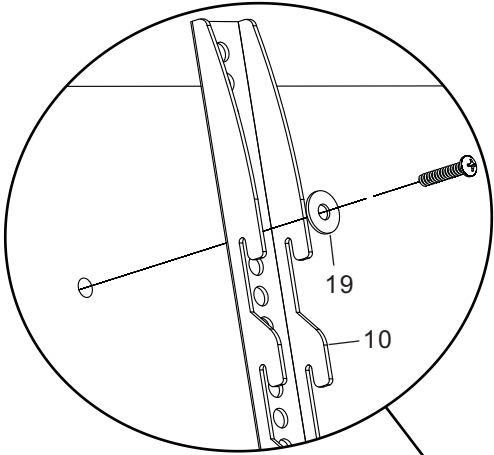

M6 Diameter Bolt

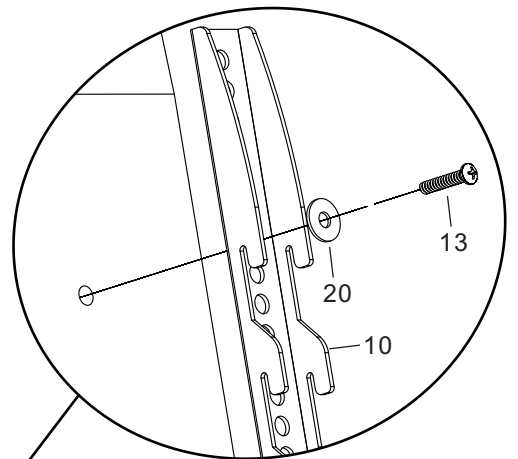
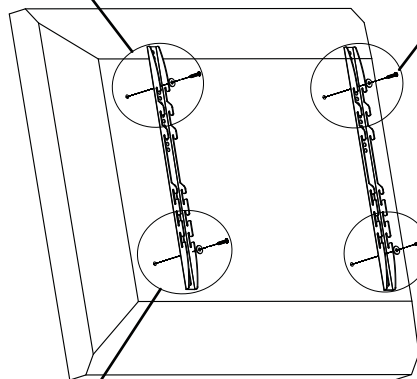
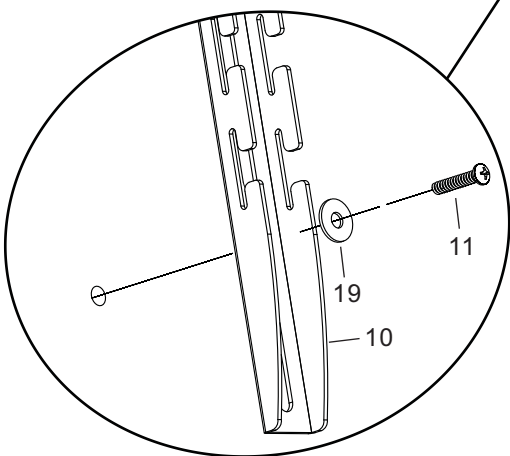

Diagram 1



M5 Diameter Bolt



M8 Diameter Bolt

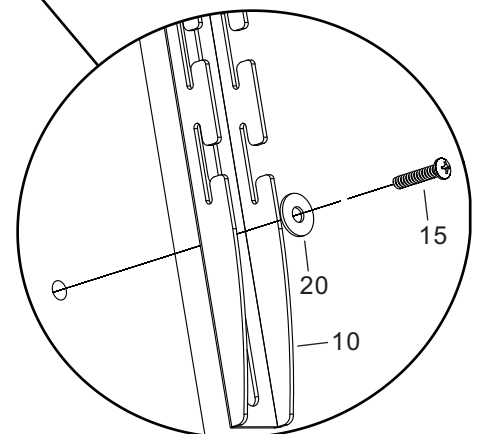

Step 6: Mounting Monitor Brackets to a television with a curved back, recessed threaded inserts or any other obstruction.

First, determine the diameter of the Bolt(12,14,16) your TV requires by hand threading them into the threaded insert on the back of the TV. If you encounter and resistance, pls stop immediately! Once you have determined the correct diameter, see the appropriate diagram below. You will thread the Bolt through the Washer(19,20), the Monitor Bracket(10),a spacer(17,18) and finally into the TV. For the M4 or M5 diameter bolt, you will need another M4/M5 Washer between the Monitor Bracket and the Spacer. Make sure the Monitor Brackets are vertically centered and level with each other.

M4 Diameter Bolt(have not supplied)

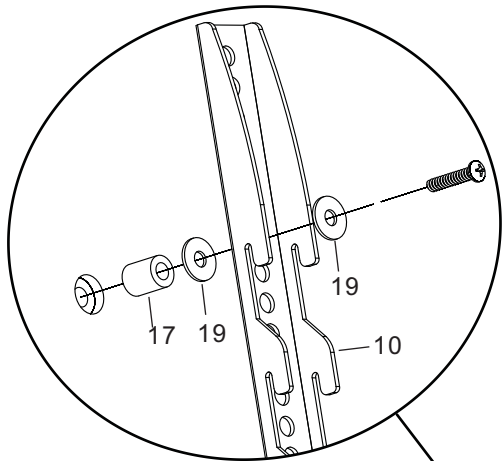

M6 Diameter Bolt

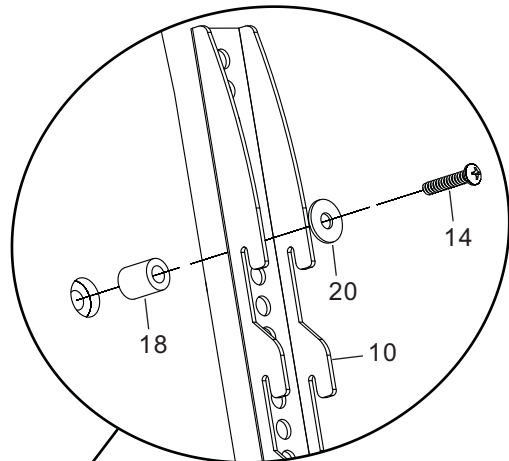
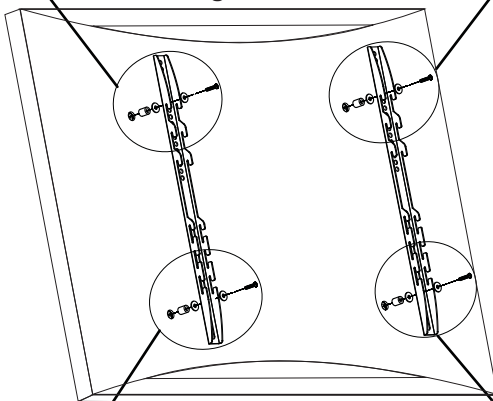
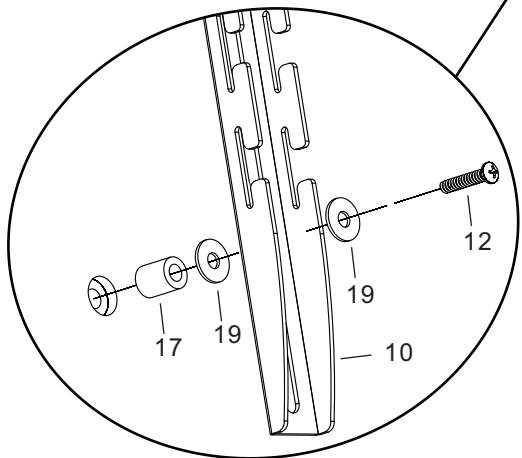

Diagram 2



M5 Diameter Bolt



M8 Diameter Bolt

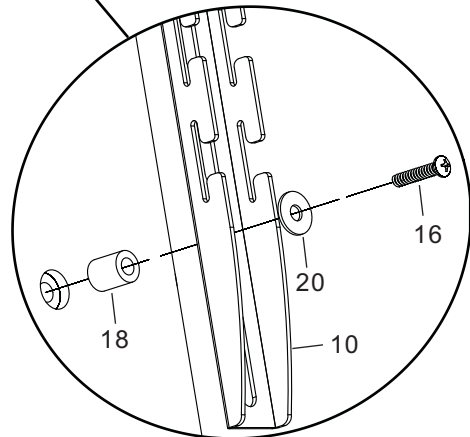

Step 7: Mounting the flat panel television to the plate.

Warning: Some televisions may require 2 people to lift! We are not responsible for personal injury or product damage.

First choose the right vertical height you want, then hook the Monitor Brackets(10) over the top of the Plate(9) as shown in the diagram. Finally fix the brackets in the position by two screws.

Put four covers on the stands base.

